

User Manual of STC-8080H Thermostat

Refrigeration and Defrosting Controller

(Version 22.11.06GEN)

STC-8080H owns one sensor, two output relays to connect and control the refrigeration and the defrosting unit, by the preset aim temperature range (-40 to 50°C) and the time setting, it offers an editable delay time before an over-temperature alarm occurs.

1. Package

Controller: 1PCS; Fasteners: 2PCS; Sensor: 1PCS; Manual: 1PCS; Waterproof Cover: 1PCS

2. Specification

Input Power 220V AC ± 10% 50/60HZ; (12/24/48/110V Option)
 Maximum current 10A (Default) under 220V AC
 Sensor NTC, 25°C /10 KΩ, the sensor cable 200cm
 Protection Class IP65 to the front panel
 Storage -10°C ~ 60°C, RH<90%, without condensation
 Measurable Range -50°C ~ +99°C
 Controllable Range -40°C ~ +50°C
 Resolution 1°C
 Accuracy ± 1°C from -40°C to +50°C; ± 2°C in other range
 Power Consumption ≤ 3W

3. Interface & Operation

3.1. Front Panel & Icon

Under normal status

- 1) Hold the **Set** key for 3s to enter the setting mode;
 - 2) Hold the **▼** key for 3s to start the forced-defrosting mod; do it again to stop defrosting.
 - 3) Press the **▲** to check the Upper limit $F1$, default -10 °C;
 - 4) Press the **▼** to check the Lower limit $F2$, default -20 °C;
 - 5) Press the **Set** to check the Defrosting Cycle / Interval Time $F7$, default 8 Hours;
 - 6) Press the **Rst** to check the defrosting lasting time FB ;
- The screen will back to normal status after 3s if without operation.

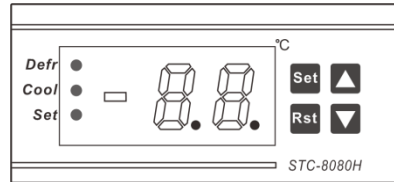

3.2. Indicator / Character

Indicator	Meaning	On	Hide	Wink
Defr ●	Defrosting status	Working	Stop	N/A
Cool ●	Compressor status	Working	Stop	Delay
Set ●	Setting Status	Setting	Normal	N/A

3.3. Dimensions & Installation

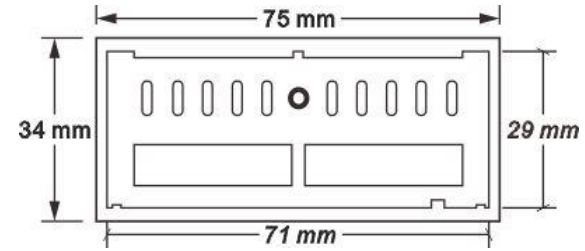

- A. Suggested amount dimension: 71*29*85+ mm (W*H*D)
- B. Detach the slide fasteners, put the controller into the hole, wiring follow the diagram
- C. Install the fasteners, and install the waterproof cover.
- D. Please **avoid** installing in the below environments:
 - Relative humidity > 90%, have condensation
 - The places that temperature < -10°C or > 60°C;
 - The places that have inflammable and explosives;
 - Strong vibration or struck
 - Exposed to the continuous water mist spraying;
 - Exposed to the dust;
 - Exposure to corrosive and pollution gas (for example, the gas, smoke, or salt fog that contain sulfur or ammonia);
 - Wireless electromagnetic interference or strong magnetic fields (near to transmitting antenna or switch board room);

3.4. Wiring Diagram

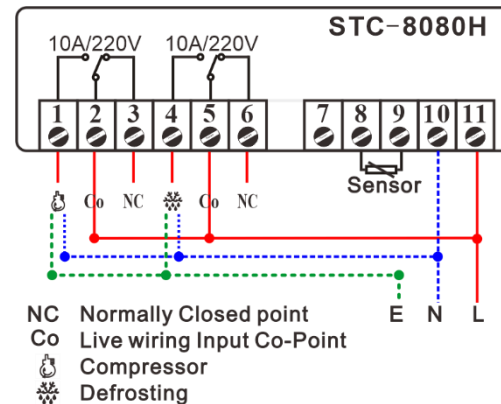

- A. 10K NTC sensor, Need not to distinguish + or - when wiring it.
- B. The input voltage must within the marked voltage ±10%.
- C. Suggest: Load Power ≤ $\frac{\text{The voltage of load} * \text{Max current of Relay}}{\text{Factor}}$

4. Configurations

4.1. Code and Function Menu

Code	Function	Min	Max	Default	Unit
F1	Temperature for Refrigeration Starts	F2	50	-10	°C
F2	Temperature for Refrigeration Stops	-40	F1	-20	°C
F3	Temperature Calibration	-5	5	0	°C
F4	Compressor Delay Time	0	9	3	Min
F5	Over-temperature to Trigger Alarm (more than F1)	0	50	15	°C
F6	Alarm Delay Time	0	99	20	Min
F7	Defrosting Cycle / Interval Time	0	99	8	Hour
F8	Defrosting Lasting Time	0	99	20	Min

4.2. How to Correct Measured Temperature?

$F3 = \text{Real Temperature} - \text{Measured Temperature}$

4.3. How to Set Parameters?

- Step1** Hold the **Set** key for 3s, and the code F1 will appear.
- Step2** Press the **▲** or **▼** keys to get the aim function you want to update;
- Step3** Press the **Set** key to check to exist value,
Hold the **Set** key meanwhile press the **▲** or **▼** key to change the value;
- Step4** Release all keys once it reaches your aim value;
Repeat operation from Step 2 / 3 / 4 to adjust other parameters;
- Step5** Press the **Ret** key to save data and back to normal monitor status.
Attention the modified value **will be saved automatically** and back to normal status if **without operation in 30 seconds.**

4.4. When will the Compressor Start/Stop Work?

Two conditions to works

- The time should be later than the compressor last stops moment + 3 minutes (not editable),
- Room Temperature $\geq F1$
In other words,
F1 is the **upper limit** to trigger refrigeration, and
F2 is the **lower limit** to stop it.

But if found sensor error, the compressor works 15mins then stops 30mins.

4.5. When will the Defrosting Start/Stop Work?

Firstly $F7 \neq 0$ and $F8 \neq 0$, and there are two defrosting modes:

A. Manual Forced-Defrosting:

Under refrigerating status, if a user holds the **Set** button for 3s, the defrosting begins at once; oppositely, this operation will stop the defrosting.

B. Automatically defrosting:

It will work according to the F7 and F8 values; time counts from the controller turn on the moment.

5. Error & Alarm

A. If $F5 = 0$, the alarm function was banned.

B. If $F5 \neq 0$, the alarm will be triggered if it reaches both of below two conditions:

- Pass the Alarm delay time (F6)
- Instant temperature $\geq F1 + F5$ or Instant temperature $\leq F2 - F5$

The buzzer is screaming when an alarm occurs; meanwhile, the readout and error code alternate display. Press any key to stop it from screaming, but the error code will not disappear until all problems were fixed.

Code	Reason	Troubleshooting
E1	memory unit broken	Press the Set key to restore the default data or get the factory reset
E2	Sensor error	Ensure the sensor was installed firmly or replace a new sensor. The alarm will disappear in 15s once the problem is fixed.
HH	$99^\circ\text{C} < \text{Instant temp.}$ $< 120^\circ\text{C}$	Check the room temperature, then change the compressor / defrosting device's working status manually if necessary.

6. Environmental Information



The package's material is 100% recyclable. Just dispose of it through specialized recyclers.

The electro components can be recycled if it is disassembled for specialized companies.

Please do not burn or throw the controllers in domestic garbage; observe the respective law in your region concerning the environmentally responsible manner of disposing of its devices.

[Video on YouTube](#)

Haswill Electronics

<https://www.thermo-hygro.com>

Copyright Haswill-Haswell All Rights Reserved

